

SUPPLEMENT STC 62-004
TO THE AIRPLANE FLIGHT MANUAL
DA 62
Business Seating Configuration
Passenger Seat Row 1

Doc. No. : 7.01.25-E
11.01.05-E
Date of Issue : 10-May-2022
Design Change Advisory : STC 62-004

This Supplement to the Airplane Flight Manual is EASA approved under Approval No. 10080349.



0.2 RECORD OF REVISIONS

Rev. No.	Reason	Chapter	Page(s)	Date of Revision	Approval Note	Date of Approval	Date Inserted	Signature

0.3 LIST OF EFFECTIVE PAGES

Chapter	Page	Date
0	9-STC004-1	10-May-2022
	9-STC004-2	10-May-2022
	9-STC004-3	10-May-2022
	9-STC004-4	10-May-2022
1	9-STC004-5	10-May-2022
2	EASA approved 9-STC004-6	10-May-2022
3	9-STC004-7	10-May-2022
4A	9-STC004-8	10-May-2022
4B	9-STC004-8	10-May-2022
5	9-STC004-8	10-May-2022
6	9-STC004-8	10-May-2022
	9-STC004-8	10-May-2022
7	9-STC004-9	10-May-2022
	9-STC004-10	10-May-2022
8	9-STC004-11	10-May-2022
	9-STC004-12	10-May-2022

0.4 TABLE OF CONTENTS

	Page
1. GENERAL	9-STC004-5
2. OPERATING LIMITATIONS	9-STC004-6
3. EMERGENCY PROCEDURES	9-STC004-7
4A NORMAL OPERATING PROCEDURES	9-STC004-8
4B ABNORMAL OPERATING PROCEDURES	9-STC004-8
5. PERFORMANCE	9-STC004-8
6. MASS AND BALANCE / EQUIPMENT LIST	9-STC004-8
7. DESCRIPTION OF THE AIRPLANE AND ITS SYSTEMS	9-STC004-9
8. AIRPLANE HANDLING, CARE AND MAINTENANCE	9-STC004-11

1. GENERAL

This Supplement describes an alternative Seating Configuration with STC 62-004 installed. The three seats of the first passenger row are replaced with two seats and a center console.

This Supplement is a permanent part of the AFM and must remain in the AFM at all times when the STC 62-004 is installed.

2. OPERATING LIMITATIONS

2.12 FLIGHT CREW

- Minimum crew : 1 (one person)
- Maximum number of occupants : 4 (four persons)
- : 6 (six persons) if OÄM 62-019 is installed

3. EMERGENCY PROCEDURES

3.13 OTHER EMERGENCIES

3.13.8 EMERGENCY EXIT

By pulling the backrest release of unoccupied seats of passenger row 1 the backrest can be flipped forward to provide an egress passage way for occupants in passenger row 2. In case of an emergency, the seat backrests can be released by pulling the red handle on the rear side of the seat pan of the passenger seats of row 1.

4A. NORMAL OPERATING PROCEDURES

No change.

4B. ABNORMAL OPERATING PROCEDURES

No change.

5. PERFORMANCE

No change.

6. MASS AND BALANCE / EQUIPMENT LIST

No change.

7. DESCRIPTION OF THE AIRPLANE AND ITS SYSTEMS

7.6 SEATS AND SAFETY HARNESSSES

For the passenger seat row 1 the business seating row 1 with two seats and a center console is installed.

The backrests of the business passenger seats row 1 can be laid forward after pulling upwards the release lever.

In case of an emergency, the seat backrests can be released by pulling the red handle on the rear side of the seat pan of the passenger seats of row 1.

A center console is installed between the two seats. The center console has an upward foldable armrest. Under the armrest is a storage box for small items like two drinking bottles or cell phones and pens. A foam insert keeps the items in position. In front of the armrest a foam insert serves as cup holder. The two cup holders must not be used during take-off, landing and under bumpy weather conditions.

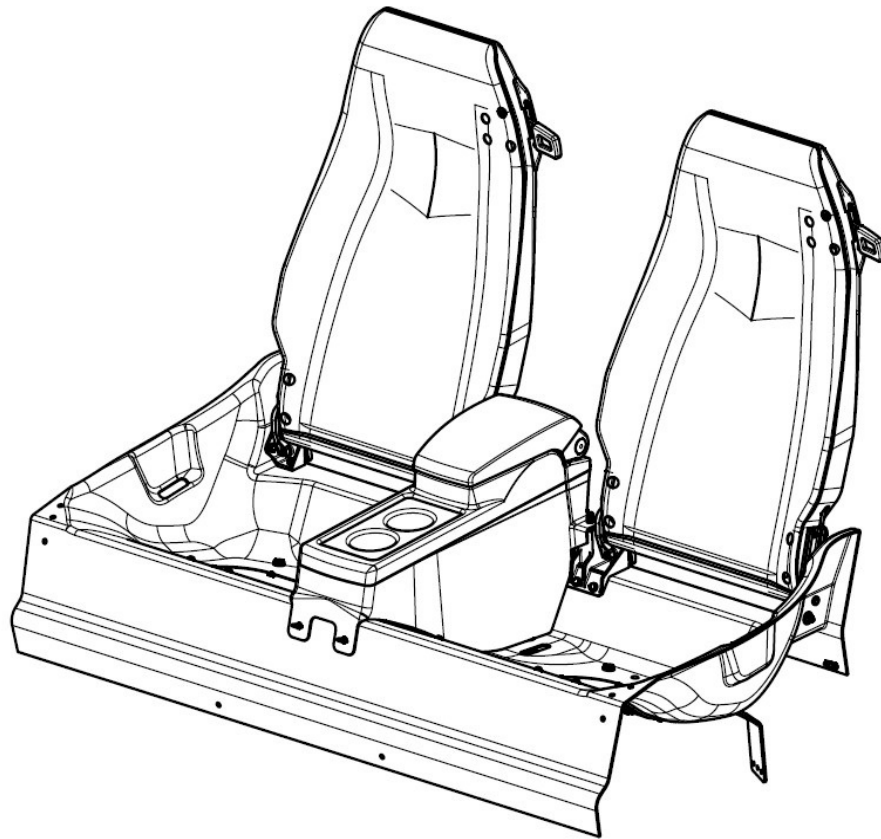

Figure 1: Business seating configuration passenger seat row 1 (STC 62-004)

8. AIRPLANE HANDLING, CARE AND MAINTENANCE

No change.



Intentionally left blank.